

Below are some helpful tips for the installation of your Tonneau cover on a Ford Ranger.

- There are three clamps per side to mount the rails to the bed. Two single bolt clamps and one double bolt clamp. The 4th clamp that is shown in the instructions was eliminated.

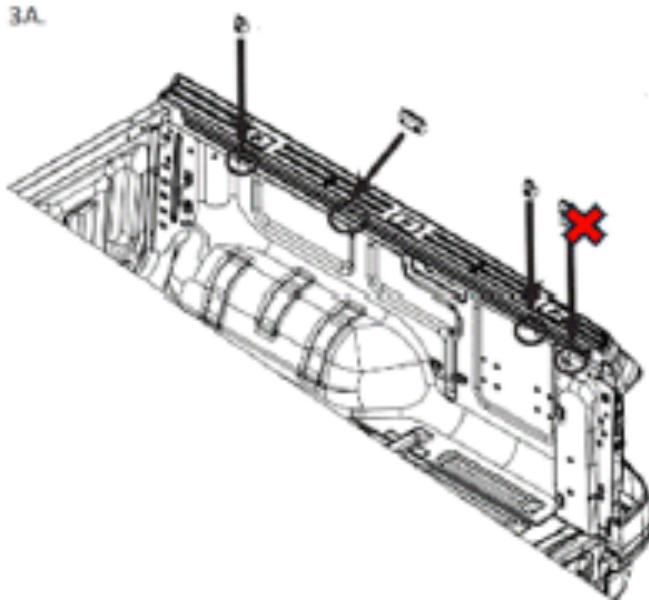

- The length of foam with the adhesive backing is to be applied across the front bulkhead of the bed. Trim it to length to fit between the plastic bed rail caps.

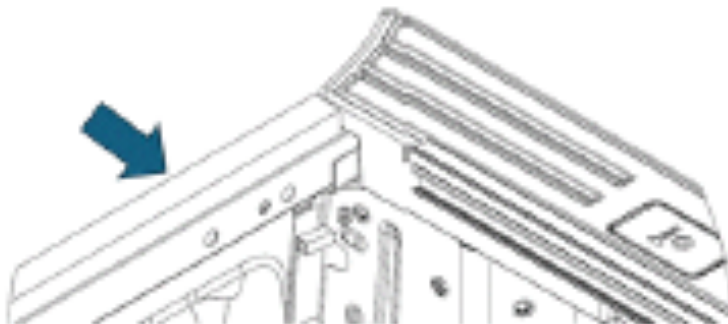

- The secondary tie downs are identical. There is not a RH or LH. Orientation is not critical; you just need to be able to hook the secondary tether to the ring once installed onto the truck. Cover not shown for clarity in the picture below.

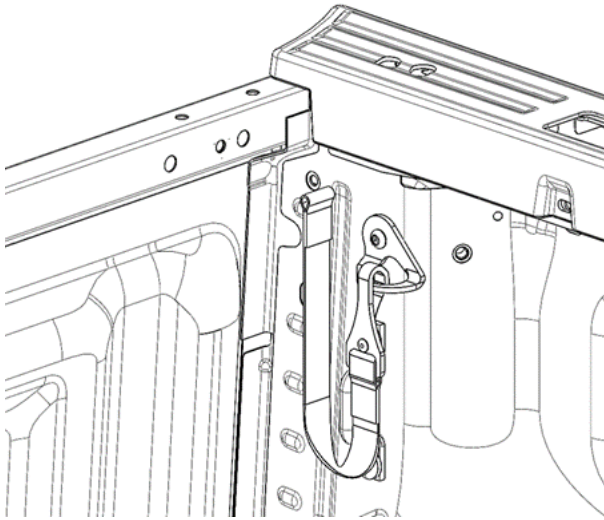

- The roll of rubber included in your hardware kit is called butyl tape. It is used to seal gaps and cracks where our seals are not able to adequately seal. You can tear off a piece of it and form it into a crack or gap to prevent water from getting into the bed. It is like a putty but very sticky. This is for use at your discretion.